



# MICRO SWITCH FOR FLOW CONTROL

Dual Line System

1655089 1655132  
1655135 1655137  
1655145 1655151  
1655160 3164126

ENGLISH

## PRODUCT DATA SHEET

### DESCRIPTION:

These micro-switches have been designed for controlling feeder blocks of the dual line system.

- **Series AP6** (adjustable discharge 0,25 to 1,5 cm<sup>3</sup>)
- **Series AG6** (adjustable discharge 0,5 to 3 cm<sup>3</sup>)
- **Modular Dual Line Feeders Series DMM** (adjustable discharge 0,3 to 1 cm<sup>3</sup>)
- **Modular Dual Line Feeders Series DM** (adjustable discharge 0,5 to 3 cm<sup>3</sup>)
- **Modular Dual Line Feeders Series DMG** (adjustable discharge 3 to 24 cm<sup>3</sup>)
- **Modular Dual Line Feeders Series DMG1** (adjustable discharge 3 to 40 cm<sup>3</sup>)
- **Modular Dual Line Feeders Series DMG2** (adjustable discharge 51 to 88 cm<sup>3</sup>)

These micro-switches are particularly suitable for controlling the correct delivery of lubricant to critical friction points.

In order to obtain a correct movement of the piston in both directions you must mount a micro-switch on the adjusting turret of the feeder and another on the opposite side.

To choose the correct micro-switch refer to fig 1.

### **Warning!**

The control of the correct movement of a metering piston guarantees that only the controlled feeder block is working but it does not guarantee that other feeders, not controlled on the same dual line, are working too. For this reason it is necessary to mount a micro-switch on each feeder block which must be controlled.

### SPECIFICATION:

**Electrical feeding:** up to 10A 250V ac. or 5A

**Protection degree:** IP 55

**Working temperature:** -15°C to +80°C

**Working pressure:** 200 bar max.

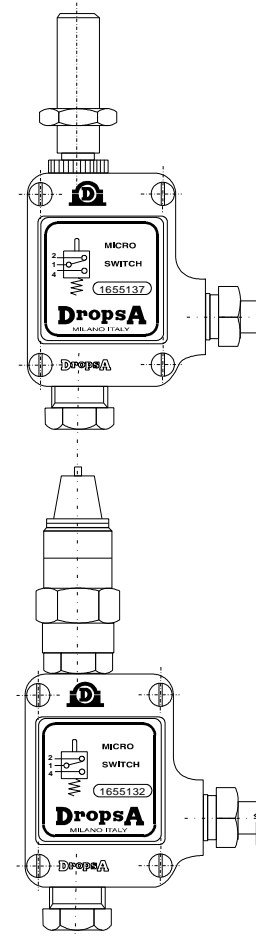

#### TURRET SIDE

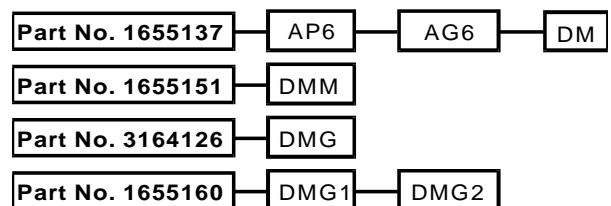

#### SIDE OPPOSITE THE TURRET

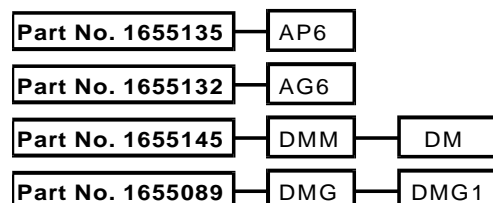

## INSTALLATION/OPERATION:

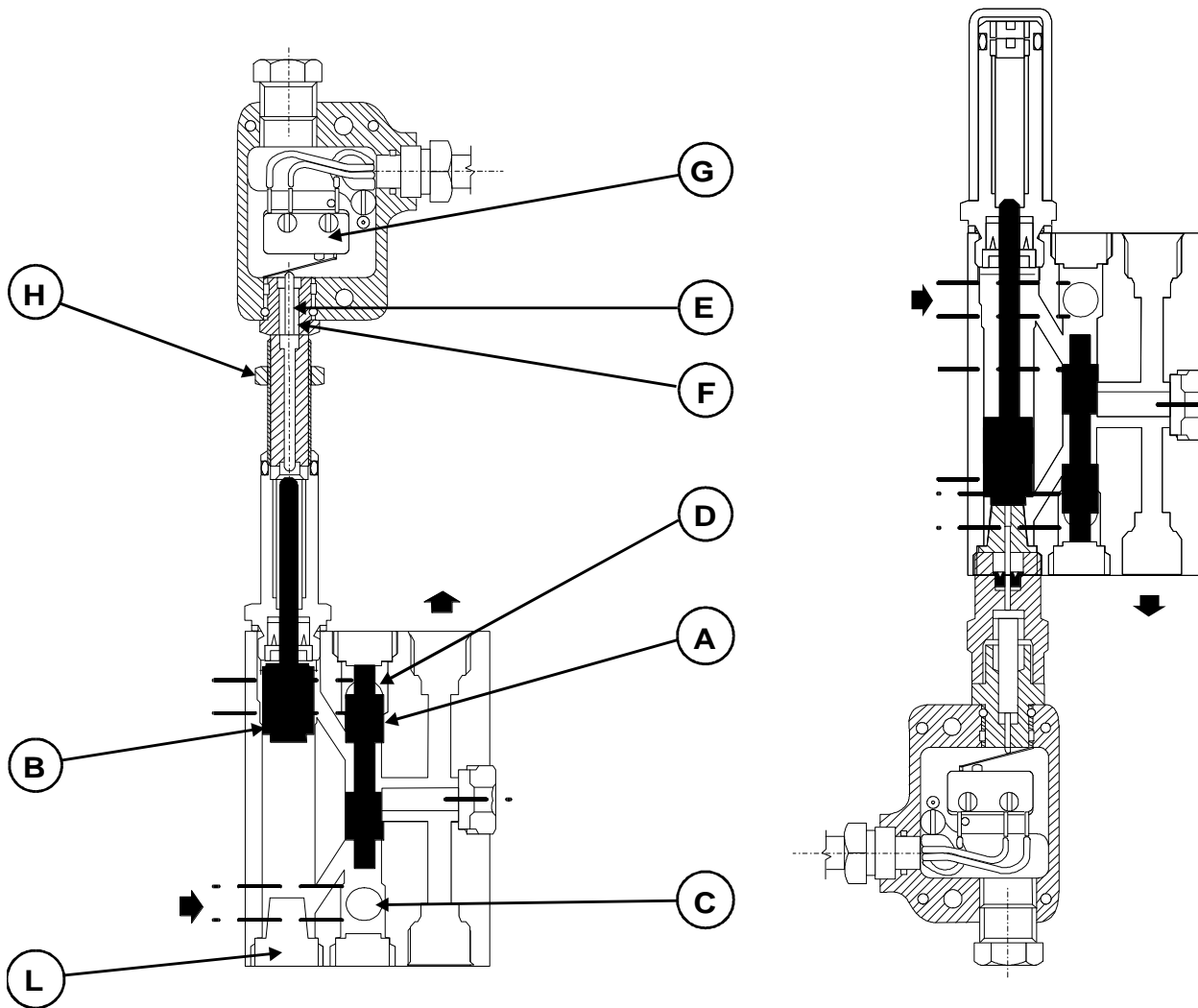

### Installing micro-switch on turret side. (fig 2.)

This micro-switch is screwed directly on the indicator turret. For the installation it is necessary to remove the turret's cover and the two adjusting screws and then screw the micro-switch on the turret; after having positioned the micro-switch on the desired delivery, tighten it by means of nut 'H'.

### Installing micro-switch on the side opposite the turret. (fig 3.)

These micro-switched are installed on the other side of the turret and replace plug 'L'.

For electrical connections please refer to the diagram on the label of the micro-switches' cover.

### Function.

The lubricant, under pressure, enters hole 'C' and moves upwards servo piston A and metering piston B (fig. 2) . Piston B's pin pushes pin E on the micro-switch, compresses spring F and activates contact G, thus signalling that the stroke of the metering piston has taken place. When pressure alternates from line 1 to line 2, the lubricant enters from hole S, pushes downwards pistons A and B and switches contact G. If required, an additional micro-switch can also be installed on the opposite side of the indicator turret, thus signalling the return stroke of the piston (fig. 3).

### Maintenance.

The mechanical and electrical components of the units are not subject to particularly heavy thermal or mechanical treatment. For spare micro-switch G, only order part no. 38031.

#### ITALIA

Dropsa SpA  
t. +39 02-250791  
f.+39 02-25079767

#### U.K.

Dropsa (UK) Ltd  
t. +44 (0)1784-431177  
f. +44 (0)1784-438598

#### GERMANY

Dropsa GmbH  
t. +49 (0)211-394-011  
f. +49 (0)211-394-013

#### FRANCE

Dropsa Ame  
t. +33 (0)1-3993-0033  
f. +33 (0)1-3986-2636

#### CHINA

Dropsa Lubrication Systems  
(Shanghai) Co., Ltd  
t. +86 (021) 67740275  
f. +86 (021) 67740205

#### U.S.A.

Dropsa USA Incorporated  
t. +1 586-566-1540  
f. +1 586-566-1541

#### AUSTRALIA

Dropsa Australia Pty  
t. +61 (02)-9938-6644  
f. +61 (0)2-9938-6611

#### BRAZIL

Dropsa Do Brasil Ind.e  
Com.Ltda  
t. +55 (0)11-563-10007  
f. +55 (0)11-563-19408