

BRAVO 4.0

Manual Versions

LTC (Lubricate Time Control)

Operation and Maintenance Manual
Translation of original instructions



Manual compiled in accordance
with Directive 2006/42/EC and Directive 2014/34/EU

C2411IE WK 21/24

1. INTRODUCTION	3	10. METHOD OF USE	16
2. GENERAL DESCRIPTION	3	11. LUBRICATION CONTROL PRINCIPLE (LTC VERSION)	17
2.1. Centralised lubrication - Principle of operation	3	11.1. Cycle operation	17
2.2. Bravo 4.0 electric pump	3	12. LUBRICATION CONTROL CYCLE SETTINGS	18
3. SAFETY AND PRECAUTIONS FOR USE	4	12.1. Description of Components	18
4. PRODUCT IDENTIFICATION	5	12.2. Dip-Switch config.	19
5. TECHNICAL SPECIFICATIONS	6	12.3. Dip-Switch pause	20
6. MACHINE COMPONENTS	7	12.4. Work switch	21
6.1. Grease version	7	12.5. LED cycle	21
6.3. Oil version	8	12.6. Alarm LED	21
6.2. Grease version with follower plate	8	12.7. First Start-up	21
6.4. Ltc electronics/level sensor (valid for all versions)	9	12.8. Changing Settings	21
6.5. Minimum level	10	13. TROUBLESHOOTING	22
6.6. Connection	10	14. MAINTENANCE PROCEDURES	23
7. UNPACKING AND INSTALLATION	10	14.1. Scheduled maintenance	23
7.1. Unpacking	10	15. DISPOSAL	23
7.2. Pump unit installation (Optional)	10	16. ORDER INFORMATION	24
7.3. Installation of the pump	11	17. SPARE PARTS KITS AND ACCESSORIES	25
7.4. Hydraulic connections	11	18. OVERALL DIMENSIONS	26
7.5. SMP/SMPM dispenser installation (optional)	11	19. HANDLING AND TRANSPORT	27
7.6. Electrical connection	11	20. PRECAUTIONS FOR USE	27
7.6.1. Connection types	12	20.1. Lubricants	28
7.6.2. Manual versions	12	21. CONTRAINDICATIONS FOR USE	29
7.6.3. LTC versions	13	22. RESIDUAL RISKS	30
8. INSTRUCTIONS FOR USE	14		
8.1. Actions to be carried out before the first USE	14		
8.2. Use	14		
8.3. Adjustable pump unit setting	14		
8.4. Tank filling	15		
8.5. Tank filling (follower plate version)	15		
8.6. Tank filling (<i>spatula version</i>)	16		
8.7. Tank filling with manual pump kit (all versions)	16		
9. USE	16		

1. Introduction

This operating and maintenance manual refers to the **Bravo 4.0 electric pump** and contains important information to protect the health and safety of personnel using this equipment. The latest version of this manual is available from the Technical-Commercial Office or from our website www.dropsa.com.

Please read this manual carefully and keep it in a safe place so that it is always available to operators who wish to consult it.

2. General description

2.1. CENTRALISED LUBRICATION - PRINCIPLE OF OPERATION

Centralised systems are designed for automatic lubrication of friction points. These systems considerably reduce the maintenance costs of the machines on which they are installed, eliminating downtime due to lubrication operations and extending the life of the lubricated components. Additionally, a centralized lubrication system makes it possible to lubricate points to be lubricated at frequent intervals, especially those that would otherwise be hard to access.

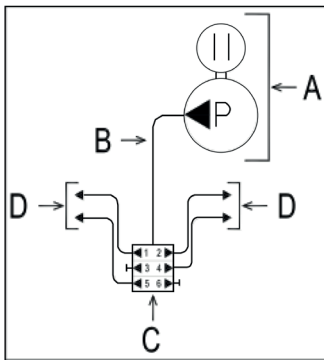

Below is a diagram of a central lubrication system in its simplest configuration; it consists of the following components:

A – Electric pump with tank

B – Primary lubrication line for distributing grease

C – Distributor element that meters grease into a number of points

D – Secondary tubing that delivers grease to the lube point

Through the primary hose (from the pump unit) the electric pump feeds a distributor which serves to distribute and control the flow of lubricant among the various friction points.

Bravo 4.0 is designed for supplying central lubrication systems in vehicles, plants and machinery with grease max. NLGI 2 and oil min. 46cSt. Any use other than what is intended is considered non-compliant.

2.2. BRAVO 4.0 ELECTRIC PUMP

The Bravo 4.0 electric pump is a piston pump driven by an eccentric system, designed to operate with up to three pumping units, making it possible to feed several independent lines or combine the outlets of two or three mounted pumping units to double or triple the flow rate.

It is supplied, as standard, with a 4cc pump unit and is available with tanks with a capacity of 2, 4, 6, 10, 14 litres for the oil/grease version and 2, 4, 8, 12 kg for the grease version with follower plate and equipped with a magnetic minimum level sensor. The pump can be supplied in the manual version or the LTC (Lubricate Time Control) version.





The main body of the pump is made from high performance robust plastic and is compact in size designed to withstand tough environments.



















In the grease versions, the system with a shaped spatula and a tank seal eliminates the presence of air bubbles in the lubricant contained in the pump, ensuring correct operation even at low temperatures. The electric gear motor, of the worm and helical-wheel type, with low-voltage direct current, is driven directly by the operator (vers. Man.) or via control programming (vers. LTC) which can be set in three different modes (see section 11).

3. Safety and precautions for use

It is important to read this manual before performing any operation. It is always recommended that the safety regulations of the country in which the equipment is installed be observed and that specialised personnel be used in the various maintenance, use, installation, etc. operations required during the life of the equipment.

Safety instructions and symbols in accordance with ANSI Z535, ISO 3864 and ISO 7010 are used in this manual and are listed below:

WARNING TABLE			
Warning	Damage to	Definition	Consequences
 HAZARD	People	Indicates a dangerous situation which, if not avoided, will certainly result in death or serious injury.	Death or serious injury, paralysing.
 WARNING		Indicates a dangerous situation which, if not avoided, could result in death or serious injury.	Possibly death or serious injury.
 CAUTION		Indicates a dangerous situation which, if not avoided, could result in minor or moderate injury.	Possible slight to moderate injuries.
 NOTICE	Things	Indicates practices not related to personal injury. Suggestions or other information.	Damage to property not to persons.

SYMBOL TABLE					
DANGER		PROHIBITION		OBLIGATION	
	General danger		Generic prohibition		Generic obligation
	Laser beam hazard		No smoking or open flames		It is mandatory to read the instructions
	Electricity hazard		Prohibited to enter with watches and metal objects		Hearing protection must be used
	Danger hot surface		Do not touch		Eye protection must be worn
	Danger vessel pressurised		Do not extinguish with water		It is mandatory to ensure the earth connection
	Danger of crushing hands				It is mandatory to disconnect the power supply
	Danger explosive area				Protective gloves must be worn

4. Product Identification

A plate on the side of the pump shows the product code, power supply voltages and basic specs.



WARNING

It is forbidden to remove the pump name plate.



NOTICE

The pump includes some components made from alloyed metals which have a lead content (CAS 7439-92-1) < 0.35% by weight. See disposal chapter for details.

5. Technical specifications

GENERAL TECHNICAL CHARACTERISTICS

Power supply voltage	DC		AC - 50Hz		AC - 60Hz	
	12 V	24 V	110 V	230 V	110 V	230 V
Current (nominal)	1.5A	0.7A	0.3A	0.2A	0.3A	0.2A
Number of outputs (pumping units)	1 (3 max.)					
Outlet thread	G1/4"					
Nominal output per pump element (20 RMP)*	4 cm ³ /min (0.24 in ³ /min) 0.6–4 cm ³ /min (0.04–0.24 in ³ /min) - Adjustable					
Working pressure	350 bar (4061 psi)					
Tank capacity Oil/grease versions	2 - 4 - 6 - 10 - 14 Lt (0.53 - 1.05 - 1.58 - 2.64 - 3.7 US gallons)					
Tank capacity Grease versions w/follower plate	2 - 4 - 8 - 12 Lt (0.53 - 1.05 - 2.11 - 3.17 US gallons)					
Max Grease consistency	NLGI 2					
Oil viscosity min.	46 cSt					
Operating temperature	-25°C - +80°C					
Storage temperature	-30°C - +90°C					
Humidity	90%					
Degree of protection	IP69K (vers. Din 72585/UTS) IP67 (vers.M12) IP64 (extra-cycle key)					
Noise	< 70 db (A)					

TECHNICAL SPECIFICATIONS LTC (Lubricate Time Control) ELECTRONIC SHEET

Operating Voltage	12VDC	±20%	
	24VDC	±20%	
	110VAC	Internal power supply	
	230VAC		
Hardware features	Reverse polarity protection on power supply Protection against power supply disturbances (Spike) Remote indication of cycle status and alarm Cycle control via external sensor Starting with external inputs Reset/Extra-cycle via external button		
3 Input signals	PNP	Same supply voltage	
2 Output signals	NPN	Digital output, maximum 2 amps per output	

MINIMUM LEVEL TECHNICAL SPECIFICATIONS

Max. load	MANUAL Version	0.25A @ 120 V
	Optical level version	Pin 2 - 1A Pin 4 - 100mA @ 24V (Dedicated power supply)



WARNING

Do not power the machine using voltages other than the ones indicated on the rating plate.

NOTICE

The indicated flow rate value refers to the following test conditions: grease with consistency class NLGI 2, standard ambient conditions (temperature 20°C [68°F], pressure 1bar [14.5psi]), back pressure of 50bar [735psi] and rated voltage 12VDC and 24VDC.

6. Machine components

The main components that make up the pump in the various versions, accessories and related options are shown below.

6.1. GREASE VERSION

Tank Size Available
(2-4-6-10-14Kg)

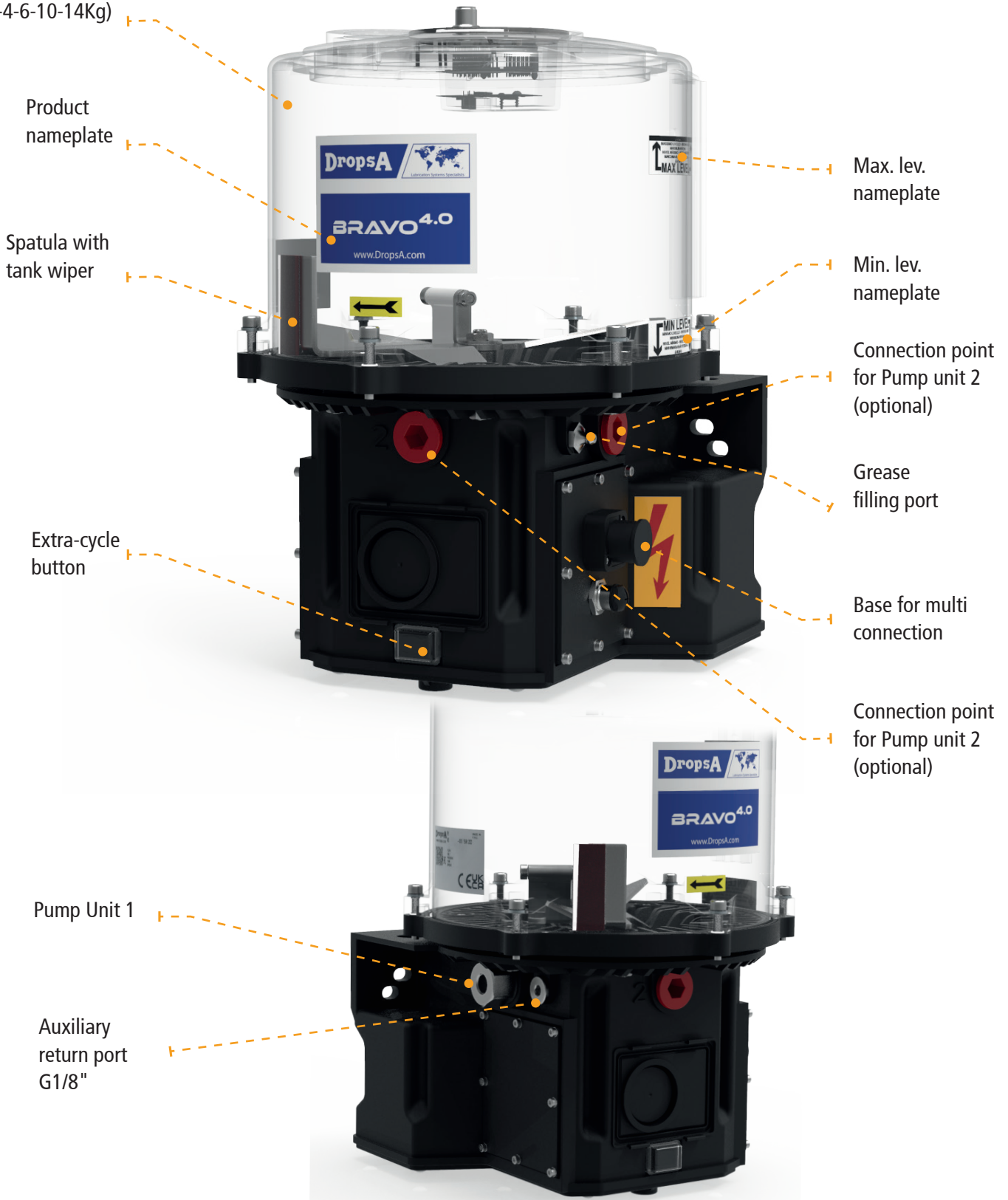

C2411E - WK 21/24

6.2. GREASE VERSION WITH FOLLOWER PLATE

Tank Size Available
(2-4-8-12Kg)



6.3. OIL VERSION

Loading cap

Tank Size Available
(2-4-6-10-14Kg)

Auxiliary return
port G1/8"

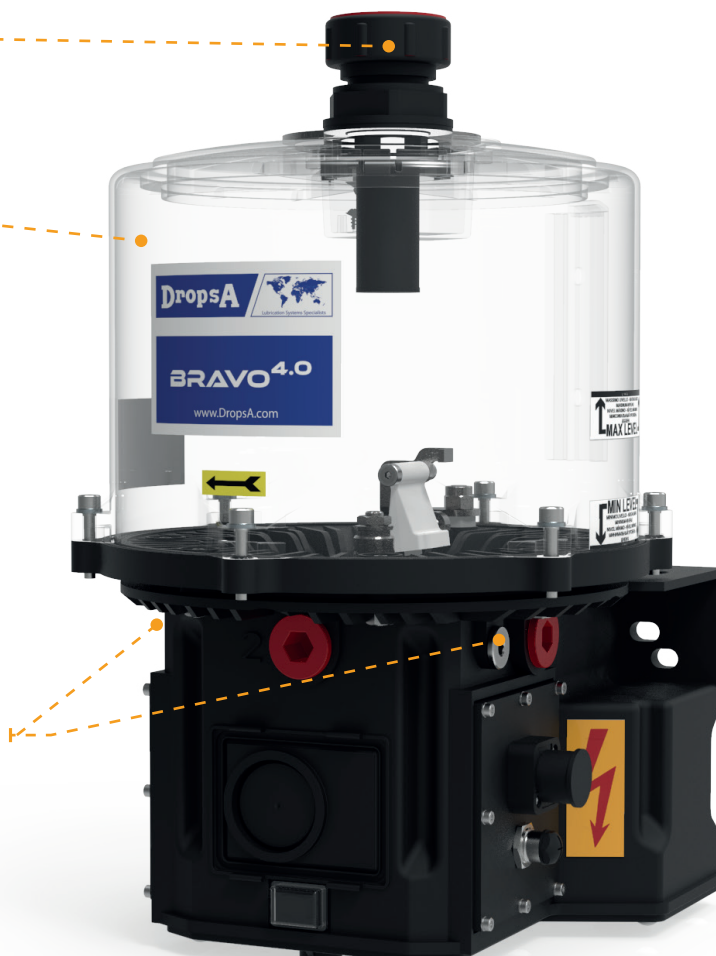



6.4. LTC ELECTRONICS/LEVEL SENSOR (VALID FOR ALL VERSIONS)

Optical IO-Link/Digital Level Connector (Optional)



Inspection window status/configuration display

	<p>⚠ WARNING</p> <p>Do not power the machine using voltages other than the ones indicated on the rating plate.</p>	
---	---	---

<p>⚠ NOTICE</p> <p>Pump output has been determined at the following conditions: grease, NLGI 2, Standard environmental conditions (temperature 20°C/68°F, pressure 1 bar), back pressure on outlet 50 bar (735 psi) 12V and 24V nominal voltage.</p>

C2411E - WK 21/24

6.5. MINIMUM LEVEL

In the manual version (N.C.) the minimum level switch opens when the minimum level of lubricant is reached.
In the automatic version LTC is only detected after one complete turn of the spatula. (see par. 11.1 Cycle function).

6.6. CONNECTION

The connection to the power supply, cycle sensor, minimum level and push-button can be of different combinations and models. These can be customised according to the customer's needs in each case managed by the configurator (see section 16).

7. Unpacking and Installation

7.1. UNPACKING

Once you have identified a suitable location for installation, open the packaging, take the pump out and make sure it has not been damaged during transport or storage. The packaging material does not require special disposal precautions, as it is not dangerous or polluting in any way. Refer to local regulations for proper disposal.



WARNING

During installation make sure that an external bypass with a maximum setting value of 320 Bar is inserted.

7.2. PUMP UNIT INSTALLATION (OPTIONAL)

The standard system comes with a single 4-cm/min pump unit installed in Port 1.
Additional pumping units (optional) can be installed on any of the free outlets: 2 and 3.

- Unscrew and remove the plastic plug with the O ring that is installed on the standard product;
- Insert and screw the pump unit in until it is fixed in place;
- Tighten the pump with a tightening torque of 22N m.



WARNING

Based on the position of the internal cam drive, it may be difficult to screw in the pump unit as it compresses the return spring. In this case, use another outlet or pay particular attention when inserting the pump unit and ensure that it does not cross-thread.

7.3. INSTALLATION OF THE PUMP

- The version with follower plate can be mounted in any position.
- Position the electric pump and use suitable screws to secure it to its support using the Ø9mm (0.354in) slots (see section 18).
- Mount the pump so that the greaser for filling the tank and the circuit board panel (auto versions only) are easily accessible.
- Leave at least 100mm (3.94in) as a perimeter distance to other equipment or obstacles that prevent access to the pump.
- Ideally, install the pump at a height that is easily and comfortably accessible by the user to facilitate maintenance and refilling.
- Do not install the pump submerged in liquid and/or in a particularly aggressive environment.
- Do not install the pump in an environment where there are explosive or flammable mixtures.
- Do not install the pump near heat sources or electrical equipment that may disrupt the correct operation of the electronics.
- Ensure that pipes and cables are properly secured and protected from impact.
- Make sure that the lubricant used is suitable for the operating temperatures, especially for temperatures below 0°C. If in any doubt, please contact our Technical Sales Office for the correct choice of lubricant.

⚠ NOTICE

The pipe must reach the point to be lubricated in the shortest possible distance.

During hydraulic connection, make sure that the pumping unit cannot rotate (screwing/unscrewing itself) by holding it in position with a 27 mm spanner.

7.4. HYDRAULIC CONNECTIONS

The hydraulic connection to the pump is via the pump outlets using adequate G1/4" fittings and pipes. It is possible to have the return in the pump with G1/8" threads.

7.5. SMP/SMPM DISPENSER INSTALLATION (OPTIONAL)

An SMP or SMPM dispenser can be installed on the pump for multi-point lubricant distribution; simply use the screws for assembly as shown in fig.1.

Tighten the screws with a torque of 2 N m.

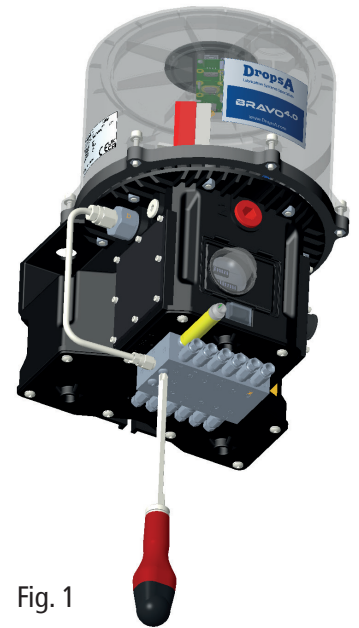

Fig. 1

7.6. ELECTRICAL CONNECTION

The electrical connection should be carried out by an electrician who understands and can identify the various connectors and wiring that have been selected for the system (operating voltage, connector types, remote control, cycle sensors).

Connect the machine to the power line as indicated on the connector board (see 7.5.1 Connection types). The power cable should be adequately chosen to ensure it can handle the current at the specified voltage.

On 110V/230VAC versions, it is advisable to install a 1A fuse T and a differential circuit breaker with a trip threshold of 30 mA and a trip time of 1 millisecond max. on the line. The insulation value of the circuit breaker should be = 10kV and the rated current $\geq 4A$.

⚠ NOTICE

Check that the electrical power supply of the pump matches that of the machine (label on the side of the tank).

7.6.1. CONNECTION TYPES

7.6.2. MANUAL VERSIONS



Type 00/01

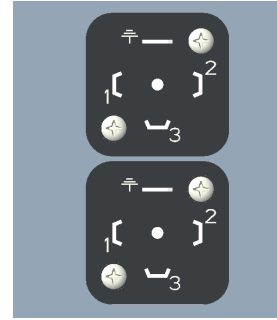

Type 02/03

CONNECTOR DIN 43650		CONNECTOR M12-4 PIN SIGNALS	
PIN	DESCRIPTION	PIN	DESCRIPTION
1	AC L / DC+	1	COMMON. SIGNALS
2	AC-DC- IN2	2	LEVEL SENSOR.NC*
3	AC-DC+ PULS.	3	-
4	EARTH	4	ROTATION SENSOR NC**

* The contact opens in the absence of lubricant.
 ** The contact opens each time the spatula completes a full revolution.
 - Not connected

1 - CONNECTOR DIN 43650		2 - CONNECTOR DIN 43650	
PIN	DESCRIPTION	PIN	DESCRIPTION
1	AC-DC+ IN1	1	COMMON SIGNALS
2	AC-DC- IN2	2	LEVEL SENSOR NC*
3	AC-DC+ PULS.	3	SENS. ROTATION.NC**
4	EARTH	4	-

* The contact opens in the absence of lubricant.
 ** The contact opens each time the spatula completes a full revolution.



Type 04/05

CONNECTOR DIN 72585 IP6K9K			
PIN	DESCRIPTION	PIN	DESCRIPTION
1	DC+	5	LEVEL SENSOR.NC*
2	DC-	6	COMMON ROTATION SENSOR
3	DC+ BUTTON	7	ROTATION SENSOR NC**
4	COMMON LEVEL SENSOR SIGNALS		

* The contact opens in the absence of lubricant.
 ** The contact opens each time the spatula completes a full revolution.

7.6.3. LTC VERSIONS

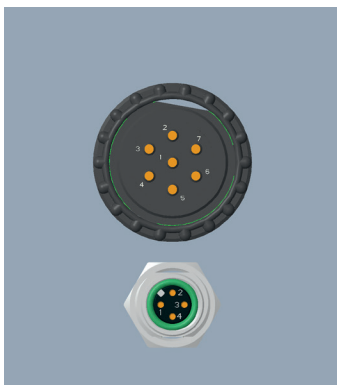

Type 50/51

CONNECTOR DIN 72585		CONNECTOR M12-4 PIN	
PIN	DESCRIPTION	PIN	DESCRIPTION
1	DC+	1	OUT - DC+
2	DC-	2	-
3	-	3	OUT - DC-
4	OUT ALARM	4	IN CYCLE
5	OUT CYCLE*	-	
6	IN RESET	-	
7	IN PAUSE	-	



Type 52/53

CONNECTOR DIN 72585	
PIN	DESCRIPTION
1	DC+
2	DC-
3	-
4	OUT ALARM
5	OUT CYCLE*
6	IN RESET
7	IN PAUSE

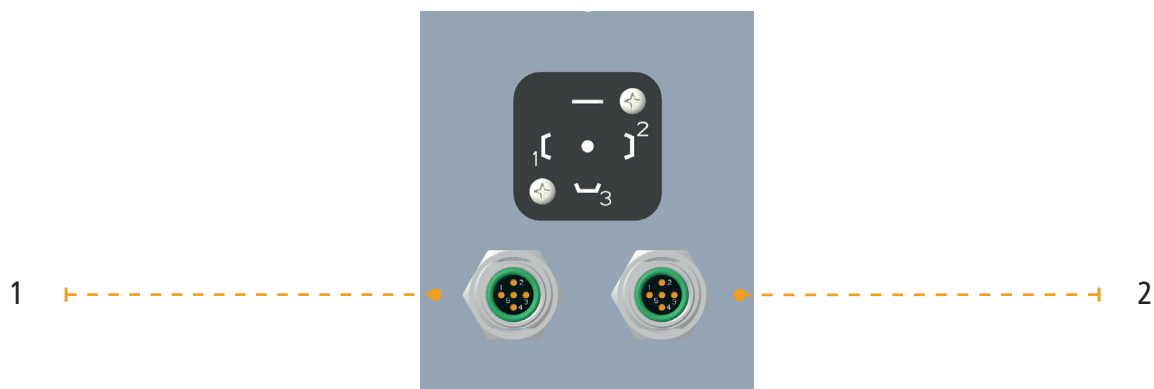

Type 54/55

CONNECTOR DIN 43650		1 – CONNECTOR M12-5 PIN		2 – CONNECTOR M12-5 PIN	
PIN	DESCRIPTION	PIN	DESCRIPTION	PIN	DESCRIPTION
1	AC L / DC+	1	OUT - DC+	1	OUT - DC+
2	AC N / DC-	2	OUT ALARM*	2	OUT CYCLE*
3	EARTH	3	OUT - DC-	3	OUT - DC-
4	-	4	IN RESET	4	IN CYCLE
-	-	5	OUT ROTATION SENSOR	5	IN PAUSE

C2411IE - WK 21/24

8. Instructions for use

8.1. ACTIONS TO BE CARRIED OUT BEFORE THE FIRST USE

- The unit can only be operated by qualified personnel;
- Do not submerge the pump in liquid or use it in a particularly aggressive or explosive/flammable environment unless it has been prepared for this purpose by the supplier in advance;
- Use safety gloves and goggles as instructed on the lubricant safety data sheet;
- DO NOT use aggressive lubricants on NBR seals. When in doubt, contact DropsA S.p.A. technical department for a detailed data sheet on recommended lubricants;
- Do not ignore health hazards and strictly follow hygiene rules;
- Always use tubes/hoses that are suitable for the operating pressure;
- Check the integrity of the pump;
- Check the lubricant level in the tank (min/max indication on the tank), if the level is low, proceed as described in Chap. 7.4 *Tank filling*;
- Check that the pump is at the correct operating temperature and tubes/hoses are free of air bubbles;
- Check that electrical devices are properly connected.

8.2. USE

- Check and set the operating mode and parameter if using the automatic version;
- Press the remote start button on your machine if using a manual version;
- Check that the pump is running;
- Check that the machine is adequately lubricated (if there is any doubt as to whether it is working properly, contact the DropsA S.p.A. Technical department to request a test procedure).

8.3. ADJUSTABLE PUMP UNIT SETTING

To set the progressive pumping unit with adjustable flow, proceed as follows:

- Ensure that there is no residual pressure in the discharge tube;
- Remove the adjustment access cap using a 4-mm Allen wrench;
- Turn the pump unit sleeve using a 4-mm Allen wrench inserted into the grub screw on the inside;
- Each full rotation of the wrench corresponds to approximately 0.8 cc/min. Adjustment range from 0.6 to 4 cc/min. for a total of 4 rotations;
- Check the presence and integrity of the copper seal (replace if necessary);
- Replace the plug using a 4-mm Allen wrench.

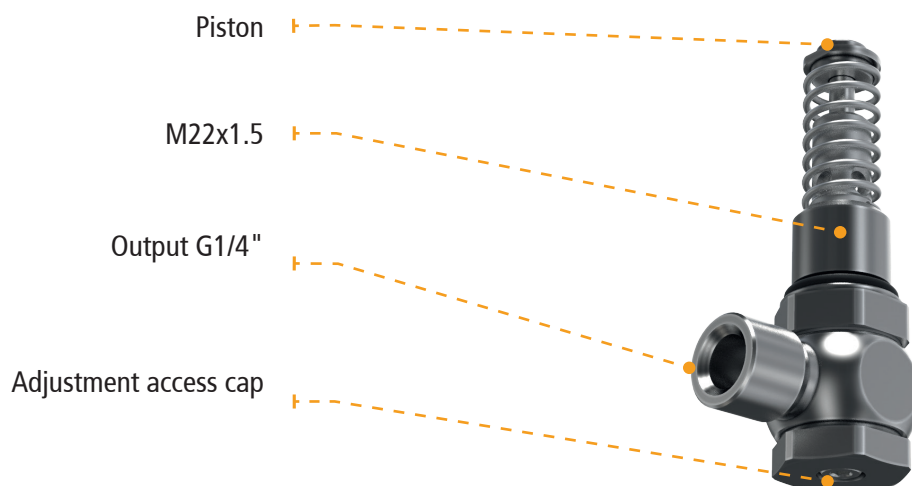

8.4. TANK FILLING

Refill the tank using the special device with filter. Proceed with filling, making sure that the maximum level line is not exceeded. If this happens, a leakage of lubricant from the vent channel, which acts as an air vent, will occur. During filling, air will be discharged directly from the hole in the vent channel itself.



8.5. TANK FILLING (FOLLOWER PLATE VERSION)

The tank is filled using the dedicated device complete with filter to be interfaced to the filling connection. If the first filling is to be carried out (with the pump completely empty, without grease), it is necessary to keep the pump vertical, so that the air in the tank can be eliminated; reaching and slightly passing the point coinciding with the line on the maximum level plate (the lubricant comes from below) will open the vent hole that will allow the air to escape. It is possible that, if the pre-set maximum level line is exceeded by a large amount, lubricant may leak out of the vent channel. The leakage will cease as soon as the follower plate returns to the working position once the surplus volume has been discharged. Subsequently, filling can also be carried out with different orientations, making sure that the maximum level line is not exceeded. If this happens, lubricant will again leak from the vent channel.

C2411E - WK 21/24

8.6. TANK FILLING (SPATULA VERSION)

The tank must be filled using the dedicated device complete with filter to be interfaced to the filling connection. During filling, air will be discharged directly from the hole in the vent channel. If the Max. level line is exceeded, lubricant will leak from the vent channel.

8.7. TANK FILLING WITH MANUAL PUMP KIT (ALL VERSIONS)

Fit, where available, the fittings for connecting the manual filling pump.

Open the tap, connect the pump to the appropriate fitting and operate the pump plunger, close the tap and detach the cartridge.



WARNING

To prevent malfunctions and voiding the warranty, it is advisable to refill with impurity-free lubricant only using the dedicated filling system.

See section 19.1 for more information about lubricant specifications

9. Use

- Check the setting data set on the control panel (if present).
- Press the start button of the machine to which the pump is connected.
- Check that the pump is running.
- Check that the machine is adequately lubricated (if there is any doubt as to whether it is working properly, contact the DropsA S.p.A. Technical department to request a test procedure).

10. Method of use

- There are no specific regulations, the pump is electrically powered by a system that controls its drive and operates the minimum level contact if the LTC board is not present.
- To operate the lubrication system, please refer to the operating and control instructions of the machine on which the pump is installed.

11. LUBRICATION CONTROL PRINCIPLE (LTC VERSION)

11.1. CYCLE OPERATION

In this version, the pump is fitted with an electronic board for lubrication control.

The control board, located inside the motor housing, gives the pump total autonomy in managing lubrication cycles, alarms and controls. Furthermore, the pump is equipped with three digital inputs for controlling the lubrication cycle, and two digital outputs for monitoring lubrication status and alarms.

The lubrication control unit with **LTC** card can be programmed to operate according to the Work-Pause lubrication principle.

This principle is based on three fundamental concepts:

- A) **Pre-Lube**
- B) **Work**
- C) **Stand-by**

A) **Pre-Lube**

If enabled via switch 1 of the Config dip-switch this phase involves execution of an entire lubrication cycle immediately after the pump has been supplied.

If pre-lubrication is not enabled, the pump will resume operation from the state before being switched off.

B) **Work**

This phase consists of a time during which the equipment performs lubrication. During this time, if enabled via switch 5 of the Config dip-switch, it is possible for the device to check the actual lubrication via an external cycle sensor. If there has been no change in the sensor status during the lubrication phase, it will only be signalled that lubrication is not correct (the cycle continues to run) via the alarm LED and the corresponding alarm output.

C) **Stand-by**

In this phase, the lubrication system is inactive until the next lubrication phase.

This phase can be set either in time mode (switch 1 of the Config dip-switch to Off) or input mode (switch 1 of the Config dip-switch to On). In both modes (Timed - Impulses), the pause count will start as soon as the lubrication phase has ended. The pump in this phase will remain stopped until the time runs out or the inputs are reached, depending on the type of pause chosen.

START PUMP

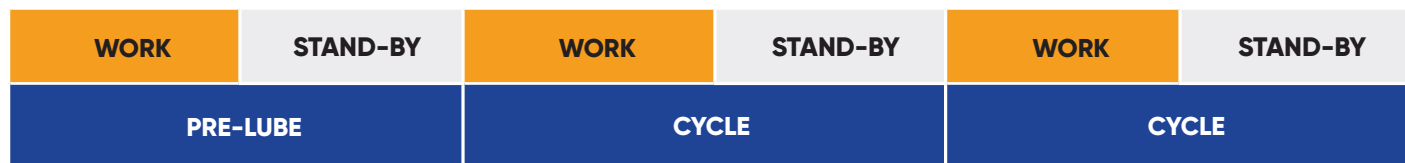

If Config - Switch 1 dip-switch to ON

C24111E - WK 21/24

12. LUBRICATION CONTROL CYCLE SETTINGS

12.1. DESCRIPTION OF COMPONENTS

Dip-switch **CONFIG**
Allows the operator to set the various pump functions

Dip-switch **WORK**
Allows the operator to set the lubrication time

STAND-BY
dip-switch
Allows the pause duration/inputs to be set





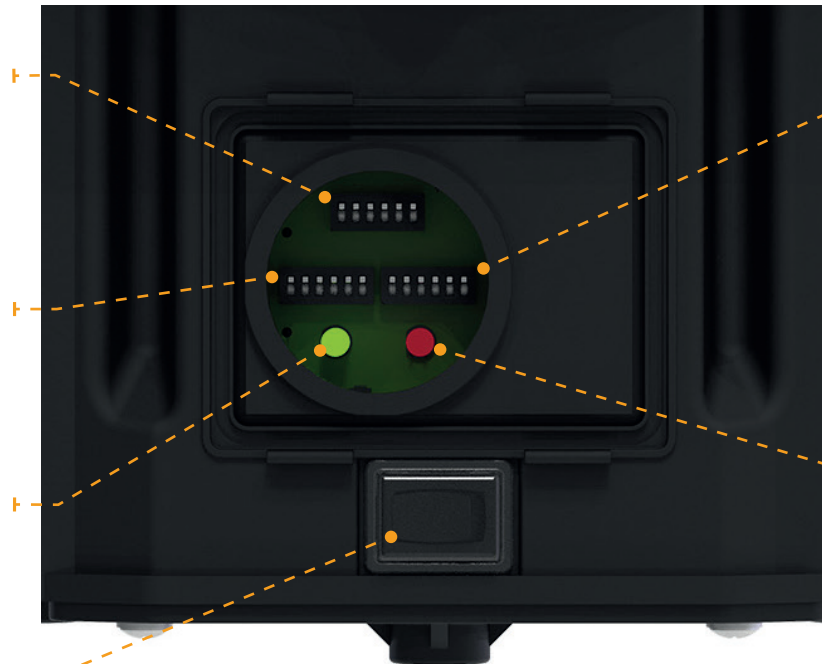

CYCLE LED
Allows the operator to check the current status of the pump

ALARM LED
Allows the operator to check the status of alarms

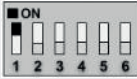
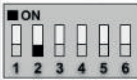
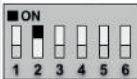
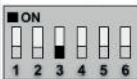
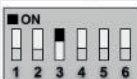
Reset/Extra Cycle button

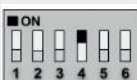

12.2. DIP-SWITCH CONFIG.

DIP-SWITCH CONFIG.				
Switch	Function	Switch Status	Function Status	Description
1	Start from		Last State	After powering up the pump, the lubrication cycle will resume from the state before shutdown
			Pre-lubrication	After supplying the pump, a new lubrication cycle will begin
2	Pause		Time	The pause is of the time type
			Impulses	The pause is of the input type
3	Pause		Scale 1	The pause value scale is 1 (Minutes)
			Scale 2	The pause value scale is 2 (Hours)
4	Work		Scale 1	The work value scale is 1 (Seconds)
			Scale 2	The work value scale is 2 (Minutes)
5	Cycle Control		Off	The pump performs no control on the cycle sensor
			On	The pump monitors the actual displacement of the cycle sensor during the lubrication phase
6	Minimum Level		Off	The pump does not stop at minimum level
			On	Pump stops at minimum level

12.3. DIP-SWITCH PAUSE

This dip-switch can be used to configure the pause time/inputs. The desired time/input can be set using the combination of one or more switches and the chosen scale via the Config dip-switch.

The table below shows the values of each individual switch.

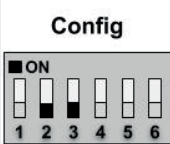
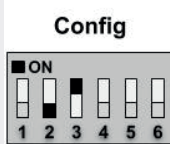
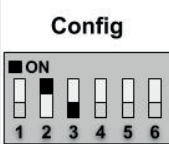
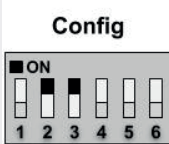
PAUSE DIP-SWITCH				
Stand-by Switch	Timed mode		Impulse mode	
	 Scale 1 (Minutes)	 Scale 2 (Hours)	 Scale 1	 Scale 2
1	1	0.5	1	50
2	2	1	2	100
3	4	2	4	200
4	8	4	8	400
5	16	8	16	800
6	32	16	32	1600
	1 to 63 minutes, step 1 minute	0.5 to 31.5 hours, step 30 minutes	1 to 63 inputs, step 1 input	50 to 3150 inputs, step 50 inputs

WARNING

At least one active switch must be present for proper operation

12.4. WORK SWITCH

This dip-switch can be used to configure the lubrication time. To set the desired time, the combination of one or more switches and the chosen scale can be set via the Config dip-switch.

The table below shows the values of each individual switch.

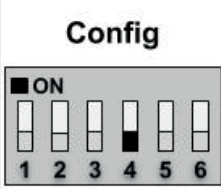
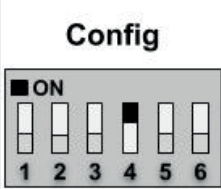
WORK DIP-SWITCH		
Work switch	Config	Config
	 With scale 1 (Seconds)	 With scale 2 (minutes)
1	1	1
2	2	2
3	4	4
4	8	8
5	16	16
6	32	32
	1 to 63 seconds, step 1 second	1 to 63 minutes, step 1 minute

12.5. LED CYCLE

The green 'Cycle' LED, depending on the current status of the pump, lights up in different modes. If the pump is in 'Stop' the light will remain off, if it is lubricating the light will remain on instead if the pump is paused the light will be flashing.

12.6. ALARM LED

The red 'Alarm' LED lights up if there is a problem with the pump, and based on the number of flashes the operator can tell what kind of alarm has occurred. If the LED flashes once per second, it means that the level alarm is present. If it flashes twice, it means that the cycle sensor control is enabled but a cycle has been completed without any change in sensor status.

To restore correct pump operation, either press the external reset button or switch the pump off and on again.

12.7. FIRST START-UP

Before starting to feed the pump, remember to fill the lubricant tank according to the instructions in section 8.4. and proceed as follows:

1. Open the inspection window in front of the dip-switches
2. Set all dip-switches to the chosen mode
3. Close the inspection window
4. Connect all connectors to the pump
5. Feed the pump
6. At power-up, the system will read the switch setting and start with that configuration. To make a change to the dip-switches, see section 12.2.

12.8. CHANGING SETTINGS



To change the dip-switch setting, proceed as follows:

1. Disconnect the pump power supply
2. Open the inspection window in front of the dip-switches
3. Adjust dip-switches
4. Close the inspection window
5. Switch the pump power back on

13. Troubleshooting

Below is a diagnostic table highlighting the main faults, probable causes and possible solutions to be implemented immediately.

If any issues and/or problems cannot be resolved, contact the **DropsA S.p.A. Technical department** rather than search for the fault by disassembling the components of the pump.

DIAGNOSTICS TABLE		
FAULT	CAUSE	SOLUTION
Pump Motor does not operate	No power	Check the power supply, ensure that any fuses installed are still intact
	controller board does not function	Replace the controller board 
	Gear motor no longer works	Replace gear motor assembly 
Pump is operating but no lubricant reaches points	Pipes are disconnected	Check the tubes/hoses and connections to the fittings. Replace the worn pipes
	Presence of air in the lower casing of the pump	Detach the pump fitting. Start the pump until the grease starts coming out. Reattach the fitting and verify that the pump distributes properly.
	Pump blocked	Disassemble and clean the pump or Replace the pumping unit.
	The progressive distributor is blocked	Unblock the progressive distributor by removing the cap corresponding to the piston and shift the position of the piston. Replace and tighten the cap and verify that the pump distributes properly. In case the fault persists, replace the progressive distributor.
The lubricant is distributed to the lubrication points in irregular doses	Distributor valves are incorrectly connected to the lubrication points	Check doses with the system diagram
	Incorrect Pause/Cycle Settings	Reprogram the pause time
The display is not lit	Incorrect power/voltage	Check that the supply voltage is as indicated on the nameplate.
No lubricant from pump	Tank is empty	Refill and check any low level alarms
	Air bubble in grease	Disconnect the primary tube/hose from the pumping unit connection. Check that clean, air-free grease is coming from the pump and then reconnect the hose
	Incompatible lubricant	Some lubricants are not suitable for automatic pumping systems. Replace the grease
	Blocked pump unit	Disassemble the pump unit and check for contamination. Clean and reinstall or replace
	Worn pump unit	Replace pump unit
	Pump unit check valve worn	Replace pump unit
The pump starts the greasing phase but ends it immediately	Defective or blocked pump motor	Allow the pump to cool and then try again. If the problem persists, it will be necessary to replace the gear motor

CAUTION





Operations to be carried out by DropsA specialists only.

14. Maintenance Procedures

The pump does not require special equipment for inspection and/or maintenance. In any case, it is recommended to use equipment and PPE suitable for use (gloves, goggles, etc.) and in good condition in accordance with current regulations to avoid personal injury or damage to parts of the pump.

The unit has been designed and built to require minimal maintenance. It is, however, advisable to always keep the equipment body clean and periodically check the tube/hose joints to promptly detect any leaks.

⚠ **WARNING**

	<p>Ensure that the electrical, hydraulic and pneumatic supplies are disconnected before carrying out any maintenance work.</p>	
---	--	---

14.1. SCHEDULED MAINTENANCE

The following table lists the periodic checks, frequency and action to be performed by the maintenance technician to ensure the efficiency of the system over time.

CHECK	FREQUENCY	PROCEDURE
Tube/hose attachments	After the first 500 hours Every 1,500 hours	Check the connection to the fittings. Check that components are correctly affixed to machine
Tank level	As needed	Top up the lubricant level in the tank
Refilling filter	As needed	Check and replace if necessary (see next paragraph)

15. Disposal

During pump maintenance, or in the event of its demolition, do not dispose of polluting parts in the environment. Refer to local regulations for their correct disposal. When disposing of the pump, the identification nameplate and any other documents must be destroyed.

⚠ **NOTICE**

The pump contains the following items made of 11SMnPb37 and 11SMnPb30: PUMP UNIT D7 0880104, PUMP UNIT D7 ADJUSTABLE 0880060, DIN GUIDE 0880040, FOLLOWER PLATE TIE ROD 088661/662/663/664.
These components have a lead content of more than 0.1% w/w and must therefore be disposed of according to current regulations.

C2411E - WK 21/24

16. Order information

The pump can be configured according to customer requirements.

The order code is derived from the above-mentioned identification string divided into two sections:

Product ID code = Product type identifier (Bravo 4.0).

Ordering option = Available product configuration options.

To see some examples, refer to page 25

PRODUCT CODE ID			ORDER OPTION			
8	8	3	X	X	X	X

TANK CAPACITY		
GREASE	2 KG	0 (*)
	4 KG	1
	6 KG	2
	10 KG	3
	14 KG	4
GREASE WITH SPATULA	2 KG	5
	4 KG	6
	8 KG	7
	12 KG	8
OIL	2 KG	A (*)
	4 KG	B
	6 KG	C
	10 KG	D
	14 KG	E
(*) OPTICAL LEVEL NOT AVAILABLE		

POWER		
MANUAL WITHOUT OPTICAL LEVEL	12 Vdc	0
	24 Vdc	1
	110/220v 50/60hz	2
MANUAL WITH OPTICAL LEVEL IO-LINK	12 Vdc	E
	24 Vdc	f
	110/220v 50/60hz	g
LTC WITHOUT OPTICAL LEVEL	12 Vdc	3
	24 Vdc	4
	110/220v 50/60hz	5
LTC WITH OPTICAL LEVEL IO-LINK	12 Vdc	H
	24 Vdc	I
	110/220v 50/60hz	L

ELECTRICAL CONNECTION		
FOR MANUAL VERSION	1X MPM + 1X M12 4PIN R SIDE (1) (2)	00
	1X MPM + 1X M12 4PIN L SIDE (2)	01
	2X MPM R SIDE (1) (2)	02
	2X MPM L SIDE (2)	03
	AMP 7 PIN IP69K R SIDE (1) (3)	04
FOR LTC VERSION	AMP 7 PIN IP69K L SIDE. (3)	05
	AMP 7 PIN + 1X M12 4PIN R SIDE (1) (3)	50
	AMP 7 PIN + 1X M12 4PIN L SIDE (3)	51
	AMP 7 PIN IP69K R SIDE (1) (3)	52
	AMP 7 PIN IP69K L SIDE (3)	53
	1X MPM + 2X M12 5PIN R SIDE (1) (2)	54
	1X MPM + 2X M12 5PIN L SIDE(2)	55
(1) STD VERSION		(1)
(2) AVAILABLE FOR 12/24V DC 110/230V AC		(2)
(3) ONLY AVAILABLE FOR 12/24V DC		(3)

Order example

FIRST EXAMPLE: 8830000

- Pump ID: BRAVO 4.0
- Tank: 2Kg grease
- Power supply: 12Vdc manual
- Connections: 1x DIN 43650 1x M12 4pin

SECOND EXAMPLE: 8836350

- Pump ID: BRAVO 4.0
- Tank: 4Kg grease with follower plate
- Power supply: 12Vdc LTC
- Connections: 1x DIN 72585 1x M12 4pin

17. Spare parts kits and accessories

OPTIONAL	
CODE	DESCRIPTION
0880104	4 cm ³ /min pump unit
0880060	0.6- 4 cm ³ /min adjustable pump unit
0010509	Screw for assembling SMP-SMPM
3134209	Grease filling cartridge kit
3130540	Greaser filter

18. Overall dimensions

Grease/Grease+Follower plate versions

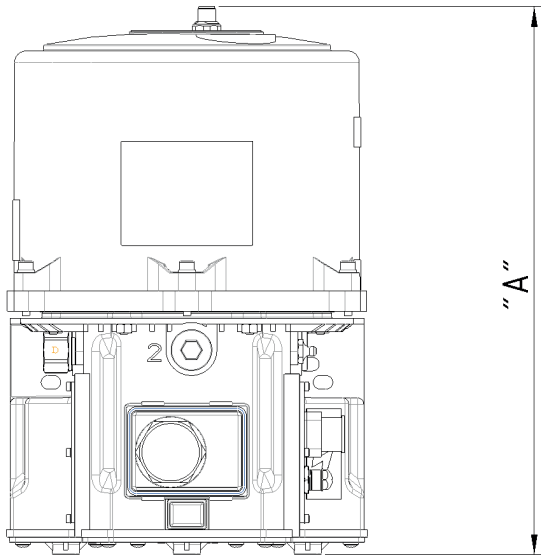

Oil versions

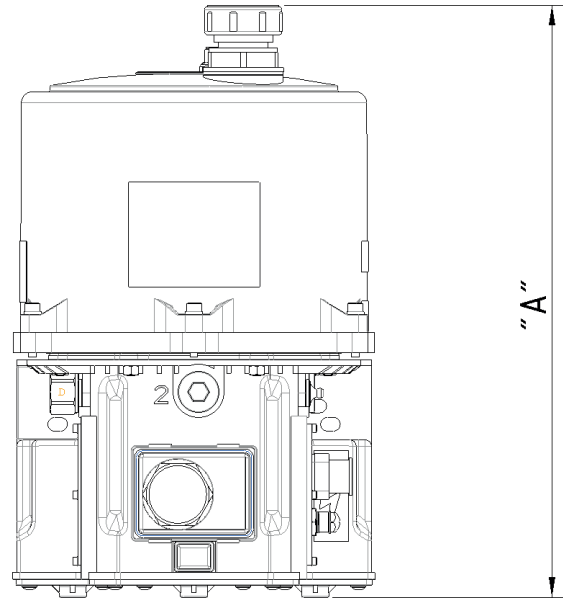

GREASE tank	VALUE 'A'	GREASE FOLLOWER PLATE/TANK	VALUE 'A'	OIL tank	VALUE 'A'
2kg tank	257	2kg tank	364	2kg tank	303
4kg tank	364	4kg tank	414	4kg tank	388
6kg tank	414	8kg tank	516	6kg tank	438
10kg tank	516	12kg tank	621	10kg tank	540
14kg tank	621	-	-	14kg tank	645

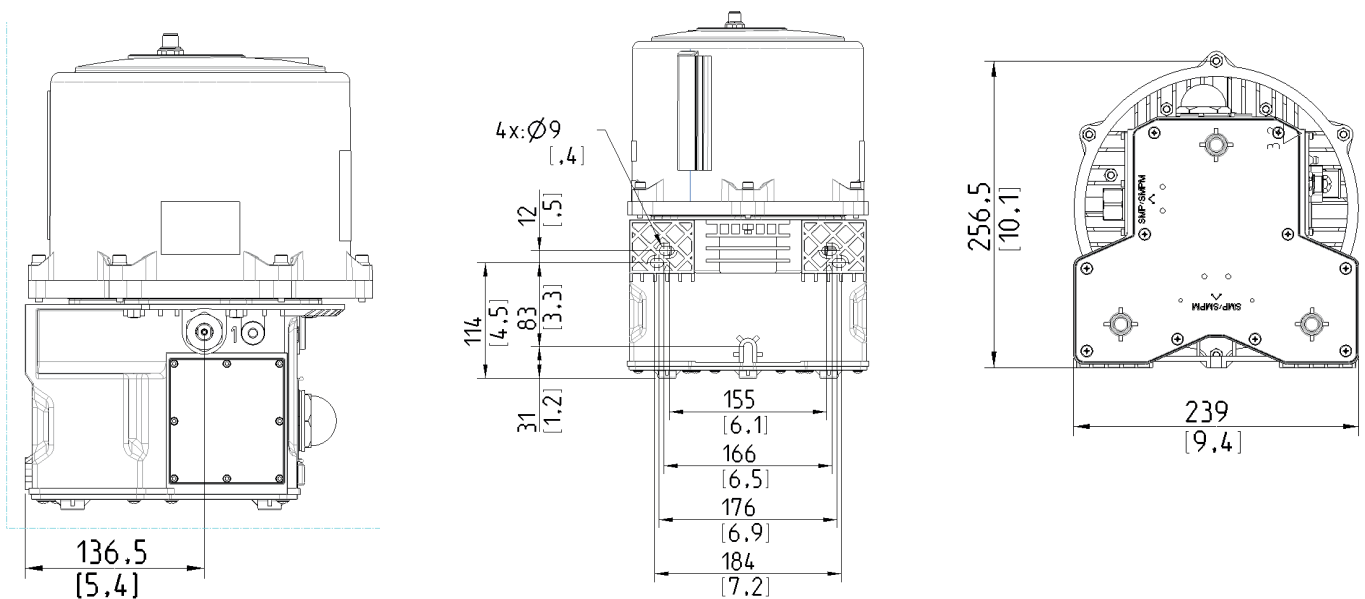

19. Handling and transport

Before shipping, the pumps are carefully packed in a cardboard box. When transporting and storing the equipment, pay attention to the orientation indicated on the box. Upon receipt, check the packaging for damage and store the pump in a dry place.

20. Precautions for use

Electrical power supply

Do not do any type of maintenance before unplugging the machine from the power supply. Make sure that no one can start it up again while maintenance is in progress. All installed equipment (electrical and electronic) must be connected to the earth line.

Flammability

The lubricant generally used in lubrication circuits is not a flammable liquid. However, all necessary related precautions must be taken to prevent it coming into contact with hot parts or open flames.

Pressure

Before any work is carried out, check that there is no residual pressure in any branch of the lubricating circuit, which could cause oil splashes when fittings or parts are removed.

Noise level

Pump produces noise, not more than 70 dB(A).

CAUTION



CAUTION: Warnings about the risks involved in using a lubricant pump should be read carefully. The user must be familiar with operation through the Operation and Maintenance Manual.

20.1. LUBRICANTS

NOTICE

The pump is designed to operate with lubricants of max. NLGI 2 (grease version) and min. 46 cSt (oil version).
Use lubricants compatible with NBR seals.
Any residual lubricant that was used for assembly and testing is NLGI 2 grade.

A comparison table between the NLGI (National Lubricating Grease Institute) and ASTM (American Society for Testing and Materials) lubricant classification for greases and between cSt (centi Stokes) and SUS (Universal Saybolt) for oils is given, limited to the values affecting the BRAVO 4.0 pump.

GREASE		OILS	
NLGI	ASTM	cSt	SUS
000	445 – 475	46	213.3
00	400 – 430	70	323
0	355 – 385	100	462.6
1	310 – 340	150	694.2
2	265 – 295	220	1018
For further information on the technical specifications and safety measures required, see the Product Safety Data Sheet (Directive 93/112/EEC) for the type of lubricant chosen and supplied by the manufacturer.		320	1480
		450	2082
		700	3239
		1000	4628

21. Contraindications for use

Verification of compliance with the essential safety requirements and the provisions stipulated in the machinery directive was carried out by compiling pre-prepared checklists contained in the technical file.

Three types of lists were used:

- Risk assessment (appendix A, EN 1050);
- Compliance with essential safety requirements (Machinery Machines);
- Electrical safety requirements (EN 60204-1).

The hazards that have not been completely eliminated but considered acceptable are listed below:

- During installation, there may be some low-pressure oil seepage from the pump. (Maintenance must therefore be carried out using appropriate PPE);
- Contact with lubricant during maintenance or tank filling. → Protection against direct or indirect contact with lubricant must be provided by the machine user. (See requirements for using suitable PPE (in accordance with current regulations);
- Moving parts and crush danger. → All moving parts are enclosed and the access point has an indication of this hazard;
- Electric shock. → It can only occur in cases of gross inexperience on the part of the user who, moreover, must be qualified;
- Abnormal operation posture. → The correct dimensions and installation instructions are given in this manual. Provide suitable means of access, such as ladders etc. or, if necessary, provide protective railings. Avoid locations near transiting work vehicles. (forklifts, etc.)
- Use of unsuitable lubricant. Lubricant specifications are indicated on the pump and in this user manual. Contact DropsA S.p.A. Technical department with any questions.

FLUIDS THAT ARE NOT PERMITTED

Fluid	Danger
Lubricants with abrasive additives	High consumption of contaminated parts
Lubricants with silicone additives	Seizing of the pump
Petrol, solvents, flammable liquids	Fire, explosion, damage to the gaskets
Corrosive products	Pump corrosion, harm to people
Water	Pump oxidation
Food substances	Contamination
H224 (1272/2008)	Highly flammable liquids and vapours
H225 (1272/2008)	Easily flammable liquids and vapours
H2265 (1272/2008)	Flammable liquids and vapours

22. Residual risks

Normal use

Do not open the pump while it is running, without disconnecting any (electric, pneumatic or hydraulic) power supply first. Chapter 14 contains the relevant warning

Maintenance

- All machine mobile parts are protected and placed inside the machine. When working inside the pump, refer to this User and Maintenance Manual, Chapter 14. In addition, cut off any (hydraulic, electric or pneumatic) power supply before carrying out any maintenance work.
- Following the risk analysis, the 'residual risks' that cannot be eliminated by the manufacturer were listed in the User and Maintenance Manual, Chapter 21, together with the requirements for personal protective equipment (PPE).

Copyright

© 2024 DropsA S.p.A. Via Benedetto Croce,1- 20055 Vimodrone (MI), Italy

This document is protected by copyright.

All rights reserved, including translation.

All rights reserved in the case of patent granting or utility model registration.

No part of this document may be reproduced in any form (e.g. printed matter, copy, microfilm or any other method) or processed, duplicated or distributed in data processing systems.

Failure to comply will lead to liability for damage. Reprints, including of excerpts, are only permitted with the approval of DropsA S.p.A.

We reserve the right to make technical changes to the machine at any time in order to improve safety, reliability, functionality and design.

All descriptions and information in this product catalogue apply to the current state at the time of creation.

We reserve the right to change the content of this document without prior notice.

We would like to point out that the software and hardware designations used in this document and the trade names of individual companies are subject to general protection under trademark or patent law.

The text and design representation may not necessarily conform to the product delivered.

Technical drawings cannot necessarily be drawn to scale.