



# END OF LINE PRESSURE SWITCH Dual Line System. PRODUCT DATA SHEET

1124402  
 1124415  
 1124440  
 1124447  
 1124456

**ENGLISH**

## DESCRIPTION:

This end of line pressure switch guarantees the correct operating pressure and the line inversion in dual line installations.

When lubricant pressure in the line reaches the pre-set value, the pressure switch controls, through the electric or electronic equipment, the lighting of a lamp and, if the installation is equipped with an electric controlled line pressure inverter, it drives the line inversion.

The end of line pressure switch comprises of:

- 1 sturdy block with 2 ¼" BSP inlet ports.
- 2 micro-switches.
- 2 pressure adjustment valves.
- 2 pressure gauges
- 2 air bleed valves.

### Types of Pressure Switch:

**Pressure switch Part No. 1124440;**

Fitted at the end of the main line, checks the correct operating pressure and, for installation with hydraulic inverter, controls the inversion from Line 1 to Line 2 and vice-versa.

**Pressostato No. 1124402:**

Same as **Part No. 1124440** but with explosion proof switch.

**Pressure switch Part No. 1124415;**

Same as **Part No. 1124440** but mounted in a waterproof box. Protection degree IP 55.



**Pressure switch Part No. 1124456;**

Same as **Part No. 1124415** but with explosion proof switch.

**Pressure switch Part No. 1124447;**

Particularly suitable for installations with many lubricant feeders and with many secondary lines.

This switch must be fitted at the end of the main line or at the end of a particularly important secondary line

And is electrically connected to another pressure switch mounted on the other end of the line. If one of the two pressure switches is not activated by lubricant pressure, the electric equipment signals an alarm to stop the machine. Only if both pressure switches are acted upon by the correct lubricant pressure, the electric equipment signals the line inversion.

## ORDERING INFORMATION:

Part No.	Electrical connections	Pressure adjustment range	Operating differential pressure*	Micro-switch features
<b>1124456</b>	Terminal board	30 to 330 bar	16 to 20 bar	250V ac. 15A Life expectancy 10 <sup>6</sup> cycles Temperature range -10°C to +85°C
<b>1124402</b> <b>1124415</b>	Terminal board	30 to 330 bar	16 to 20 bar	
<b>1124440</b>	Connector 3 poles + earth	30 to 330 bar	16 to 20 bar	
<b>1124447</b>	Connector 6 poles + earth	30 to 100 bar	12 to 14 bar	

\* Operating differential pressure = difference of pressure necessary to obtain the change of micro-switch contacts.

## INSTALLATION/OPERATION:

### Operation.

When lubricant pressure in the line connected to the pump, reaches the pre-set value on the pressure adjusting valve 1, piston 2, moves up to close the contact of micro-switch 5 which signals, through the lamp of the electric panel, the inversion of the line under pressure.

For dual line installations with an electrically controlled inverter, micro-switch 5 also commands the inversion of pressurization of the lines.

**Note: A red alarm lamp signals any malfunction of the end of line pressure switch.**

The next lubrication cycle inversion will occur in the same way as described above. The lubricant pressure in the line now connected to the pump reaches the pre-set value on the other pressure adjusting valve. The pressure in the previously pressurized line is released. This release pressure must be equal to the operating differential pressure in order to guarantee the correct delivery of lubricant from the metering valves.

The operating differential pressure is the difference in pressure necessary to open the contact of micro-switch 5, and depends on distance X between piston 2 and micro-switch 5, which must be 3,3 mm.

### Adjusting valve setting:

1. Loosen nut A.
2. Turn adjusting nut B until the desired setting value is obtained (check that the pump is operating at the correct pressure by means of the pressure gauge and verify with an Ohmmeter the change of contacts in the micro-switch).
3. Tighten nut A.
4. Repeat the same operation on the valve that controls the other lubrication line.

**Note:** by dismounting spring 4, maximum adjusting pressure will be 100 bar. In this case we advise the use of pressure gauge **Part No. 20606** (scale from 0 to 250 bar).

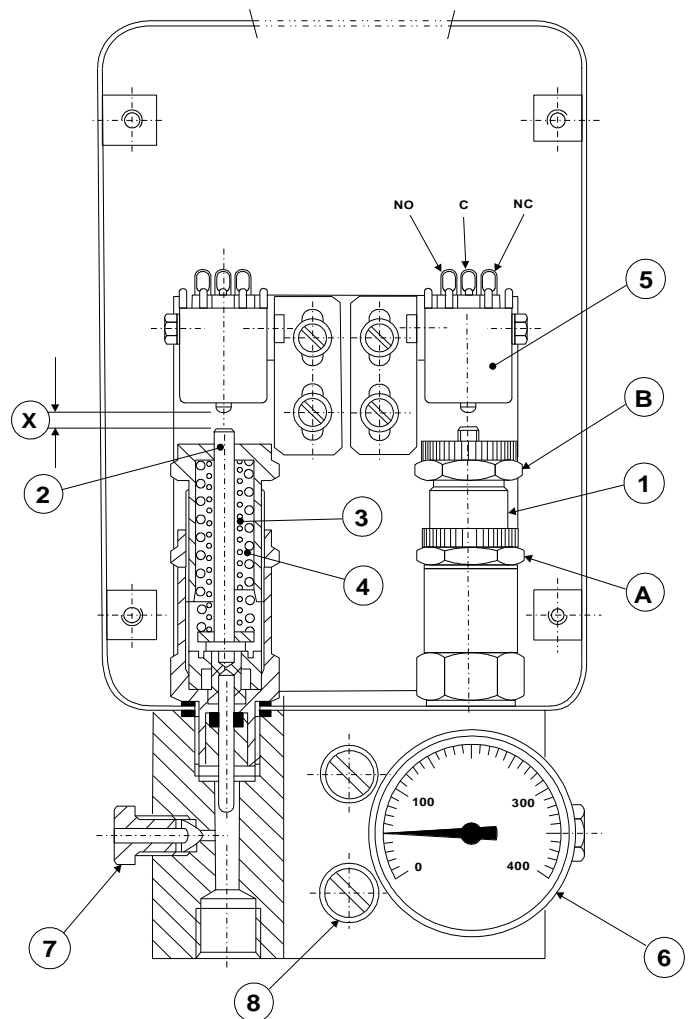

### Spare parts:

Spare parts	
Description	Part No.
1. Adjusting valve assembly	<b>1124430</b>
1. Adjusting valve assy. for <b>1124447</b>	<b>1124446</b>
2. Piston	<b>1124423</b>
3. Spring	<b>3191222</b>
4. Spring	<b>3191223</b>
5. Micro-switch	<b>38041</b>
6. Pressure gauge (0 to 400 bar)	<b>20604</b>
6. Pressure gauge (0 to 250 bar)	<b>20606</b>
7. Air bleed screw	<b>3230103</b>
8. screws	<b>12707</b>

**Pressure Switch Part No. 1124440 Electrical connections.**

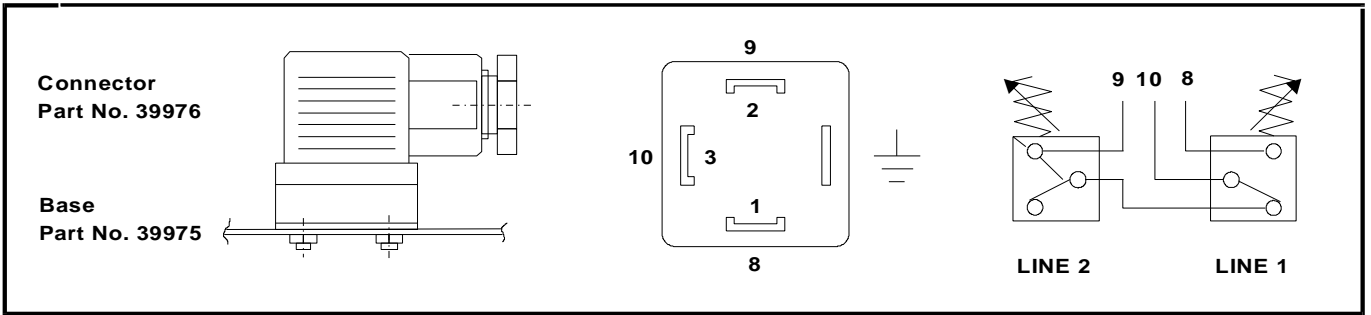

**Pressure Switch Part No.'s. 1124402 - 1124456 - 1124415 Electrical connections.**

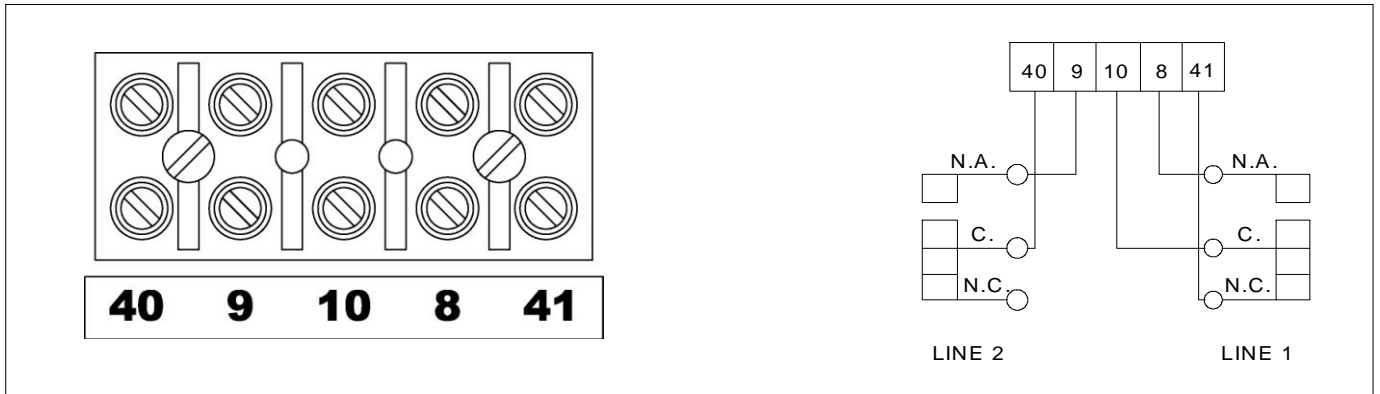

**Pressure Switch Part No. 1124447 Electrical connections block diagram.**

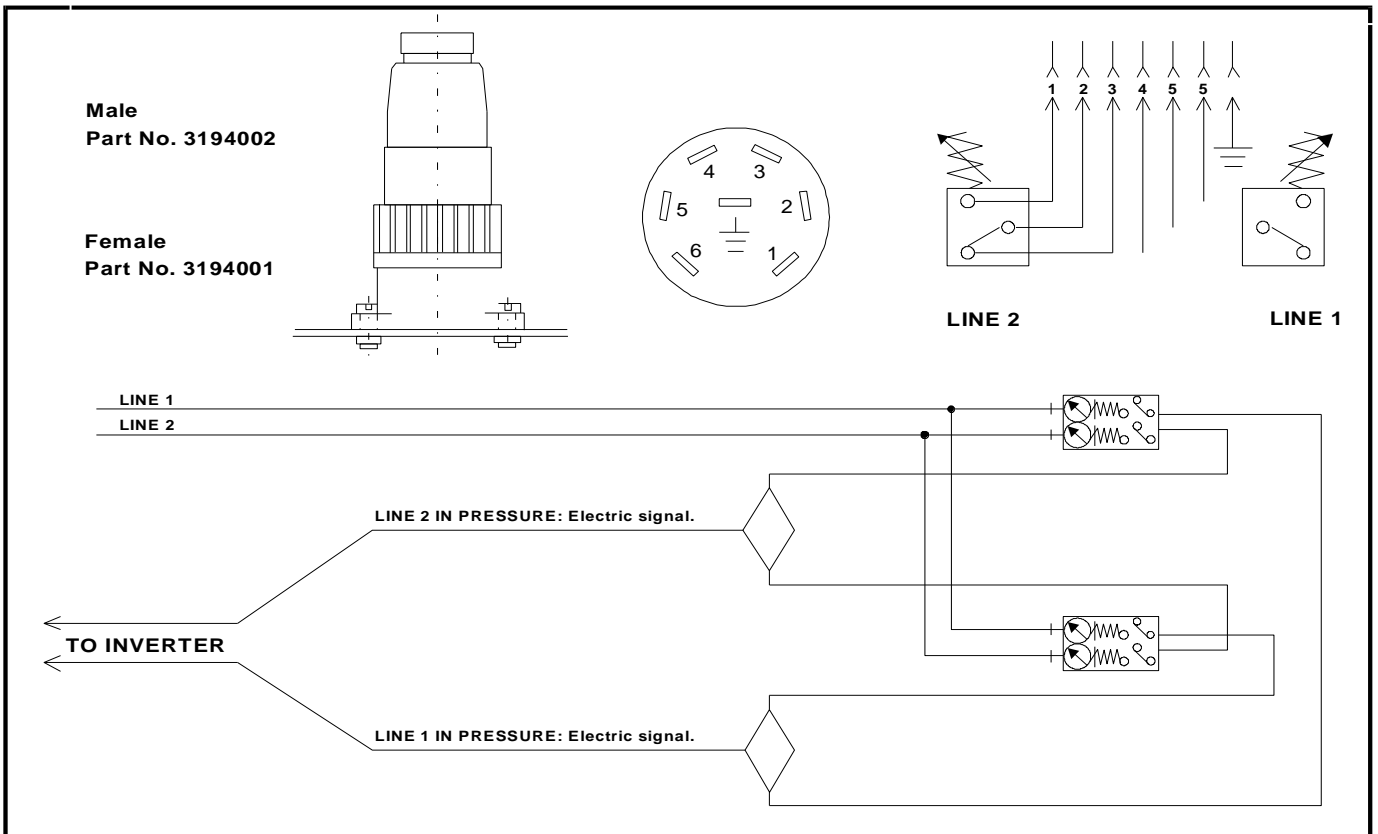

**ITALY**  
 Dropsa SpA  
 t. (+39) 02-250791  
 f. (+39) 02-2507967

**U.S.A.**  
 Dropsa Corporation  
 t. (+1) 586-566-1540  
 f. (+1) 586-566-1541

**BRAZIL**  
 Dropsa  
 t. (+55) 011-563-10007  
 f. (+55) 011-563-19408

**AUSTRALIA**  
 Dropsa Australia Ltd.  
 t. (+61) 2-9938-6644  
 f. (+61) 2-9938-6611

**CHINA**  
 Dropsa Lubrication Systems  
 t. +86 (021) 67740275  
 f. +86 (021) 67740205

**U.K.**  
 Dropsa (UK) Ltd  
 t. (+44) 01784-431177  
 f. (+44) 01784-438598

**GERMANY**  
 Dropsa GmbH  
 t. (+49) 0211-394-011  
 f. (+49) 0211-394-013

**FRANCE**  
 Dropsa France  
 t. (+33) 01-3993-0033  
 f. (+33) 01-3986-2636