



TRACK-LUBE



Dropsa BBTS Track Lube Cat. 744 992

Lubrication Systems and Solutions Specialists

TRACK-LUBE is the Dropsa BBTS lubrication system for the rail curve.

We offer a reliable and robust system, capable of resisting severe environmental conditions. The system has advanced control system that uses a network connection that communicates with a remote laptop, pc or PLC (programmable logic controller). This is possible due to its interface with a 3G connection (the SIM card must be enabled to transmit and receive 3G data).

The lubricant (NLGI grade 2) is applied onto a lubrication bar directly on the correct side of the rail.

The Track-Lube is modular which makes configuration of the system efficient and easy. A small lubrication bar applies the lubricant in a uniformed manner and is sufficient to lubricate a piece of track for 4.000 m. Its possible to install several small bars from one pump station.

This means that the Track-Lube system is very versatile. We can offer a system at competitive prices that can lubricate a single curve or offer a system that lubricates several curves on a track from a single pump station.

The system can accurately lubricate with temperatures ranging from -25 °C e + 45°C.

An alarm or notification can be sent to the PLC or Mobile phone and can signal the system's current status or any alarm status that may occur such as low level of grease. This is possible as we have a WEB interface that allows us to monitor or modify settings of the system.

The control panel has an input voltage of either 220Vac – 150Vac – 24 V DC. Alternatively a solar powered system can be used. The required power for the system is 1000 VA.



The Track-Lube system was created to lubricate the rail curve for winding track.

The modular Track-Lube system is modular. A single pump station is capable of lubricating different parts of the track (a maximum of 12 curves from one pump station). Each curve, dependant on the curve's radius, can be lubricated by one or more small lubrication bars. We use more bars if we want to increase the portion of track to be lubricated.

The 12 small bars are individually independent. Each bar can have its own vibration sensor to detect the train's position or they can run off one sensor only.

The system includes a laser sensor to monitor the continuous level of grease and displays a percentage of how much grease is remaining. This allows the user to plan a maintenance visit. The large 50 KG grease reservoir also means that planned visits can be as long as every 6 months. Data is collected remotely allowing statistical analysis of consumption. This ensures that the system is working.

The PLC with PROFINET interface allows other sensors or instrumentation to be added to the PLC as long as they are compatible with PROFINET or PROFIBUS.



The system is equipped with a backup battery that guarantees 4 hours of run time. Due to this the user also knows when there is an electrical supply breakdown either from a fixed electrical installation or solar panel failure. In the event of power loss the system sends an alarm to the user remotely using the 3G connection.

Alternatively the system is also capable of transmitting via WIFI or ETHERNET cable (with internet access) to a web server.

It is possible to access the remote plc from the unit. This is password protected to protect the remote computer.

The notification program allows the user to decide which data to send by email in case of an alarm.

The system is approved on the Italian railway network, part number (744-992).

LUBRICATION BRUSH FOR CHECK RAIL



The wear created from the inside of the wheel flange on the checkrail can be particularly costly on double switch points or on manganese switch point.

To reduce wear, which in turn reduces the interval of replacing the switch point, we developed a small bar complete with a brush to apply lubricant to the profile of the wheel flange.

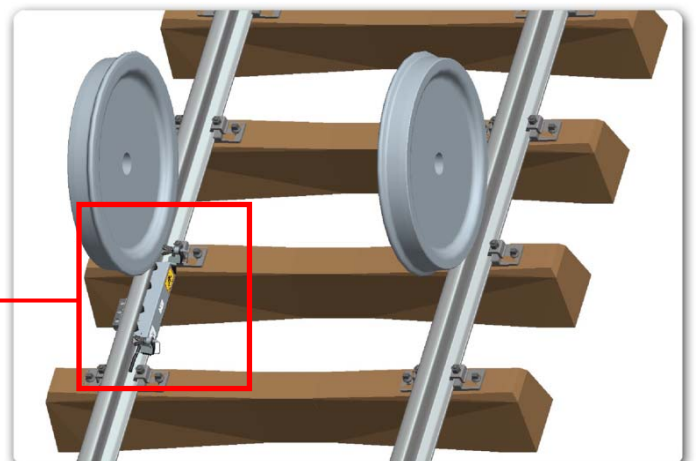
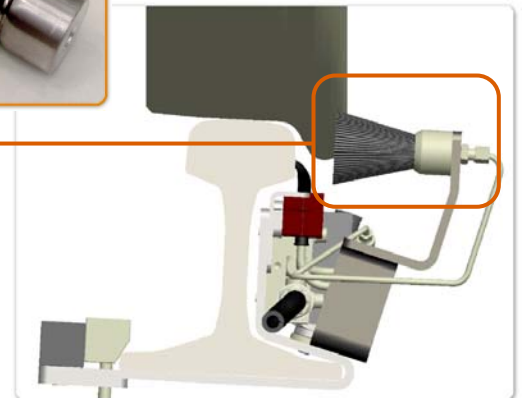
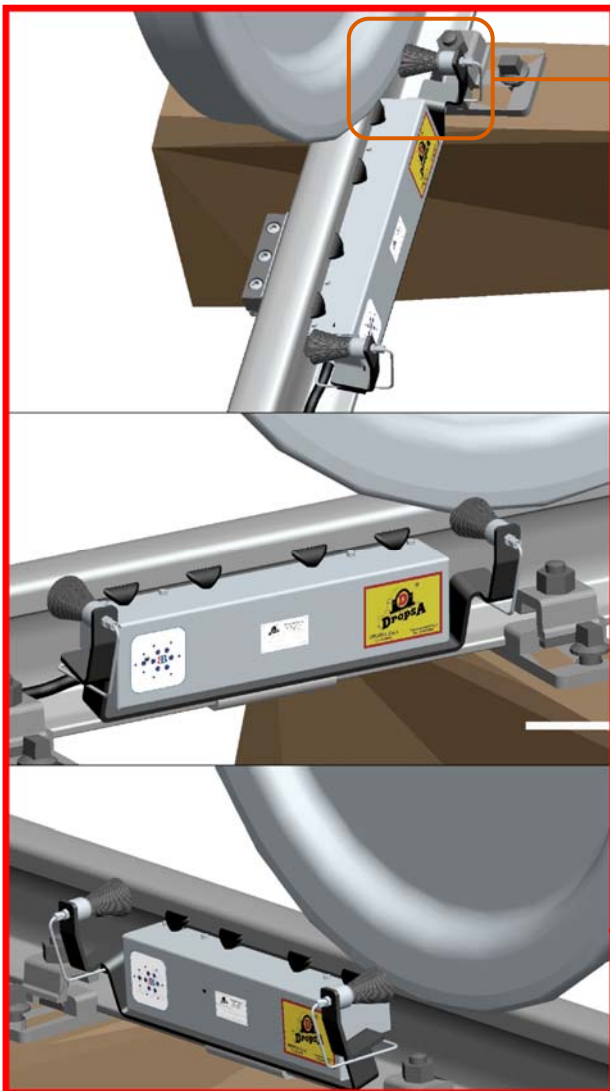

A typical Track-Lube system comprises of :

- 1 cabinet with advanced control panel, 1 electric pump for 50 KG drum, (system is capable of serving unto 12 bars), all parts inside the cabinet are tested and electrically cabled.
- 1 small bar (distributes to 4 nozzles)
- 1 kit containing a sensor to activate the system
- 1 kit containing tubes and fittings
- 1 kit containing a remote control module

Accessories

The following are some accessories that may be needed to extend the system.

- Small lubrication bars
- Solar Panel
- Heating Kit
- Grease

Its important that the user surveys the site and determines what is needed for the proper lubrication.

The user is responsible for electrical supply to the unit if solar panel is not taken as an option.

